



PUMPWORKS, Inc.

LIQUID & GAS TRANSFER TECHNOLOGY

PW2000 Series

Model **PW2003**

High flow, UL-listed, rate-controllable liquid pump for **hazardous locations**
Class 1, Div. 2, Groups A, B, C, D

FEATURES

The PW2003 is rate-controllable for infinite flow adjustability

Control options:

- Simple on/off switch
- Dry contacts
- VRC 2000 Controller
- 4-20 mA systems
- PC or PLC interface
- Custom controls available

PW2000 Series Features

- Magnetically driven
- Leak-proof
- Pump & motor in one package
- Integral solid state circuit board for easy controllability and pump protection
- Compact for flexible installation
- Quiet (<60 db)
- Sealless and oilless
- Self priming
- Dead-head and run dry capable
- Integral overload protection

Custom pumps with expanded capabilities are available



SPECIFICATIONS

Performance

(all figures are maximums, tested on water @ room temperature)

Volume	_____	46 gph
Pressure	_____	45 psig
Inlet Suction	_____	14 in. Hg
Inlet and System Pressure	_____	1400 psi
Particle Size	_____	1/32"
Fluid Temperature	_____	140 °F
Power Requirements (watts)	_____	80 - 130

Other Specifications

Weight	_____	4.8 lbs
Inlet and Discharge Port	_____	3/8" FNPT
Voltage (60Hz, 1 Phase)	_____	120V
Duty Cycle	_____	Continuous

Materials

Piston Cylinder	_____	316 Stainless Steel
Housing	_____	316 Stainless Steel
Elastomer Option	_____	Fluorel (Viton equiv.) EPDM, Neoprene
Piston	_____	Coated 416 SS
Connections	_____	Electroless Nickel Plated 416 SS

PW2003 DIMENSIONS

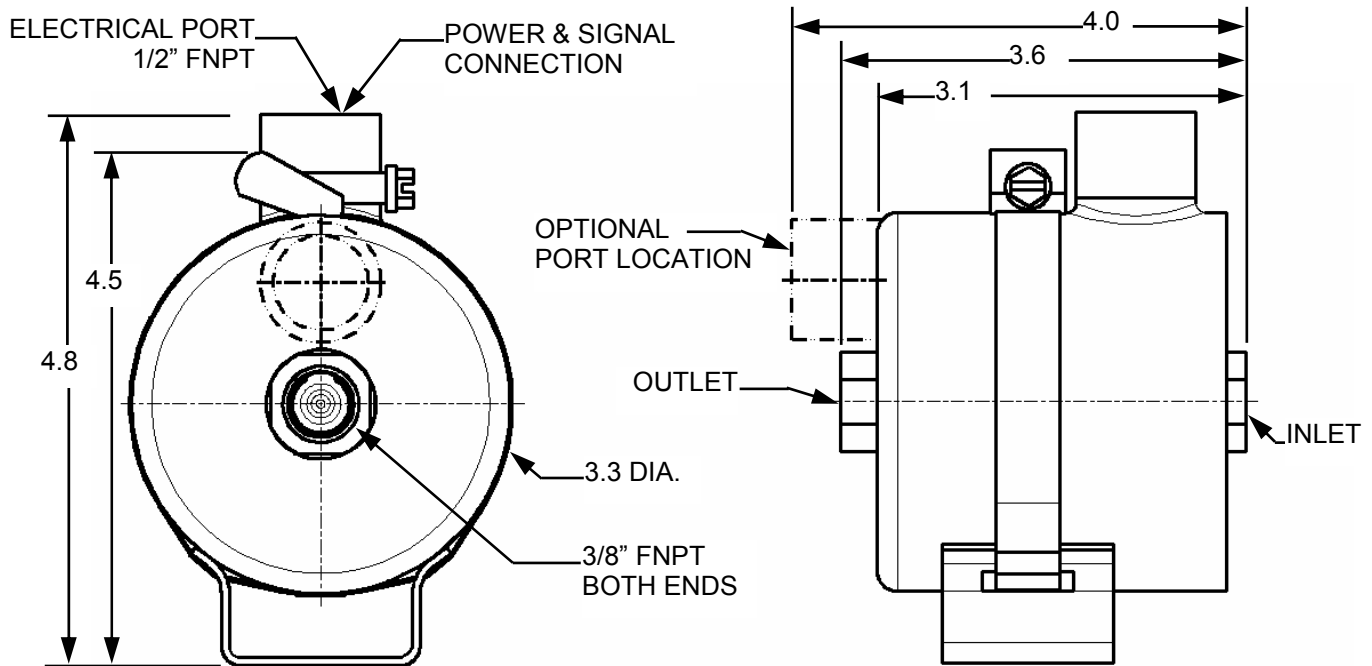

Note: All dimensions are in inches, pump shown with optional mounting kit installed

PW2000 SERIES CUTAWAY

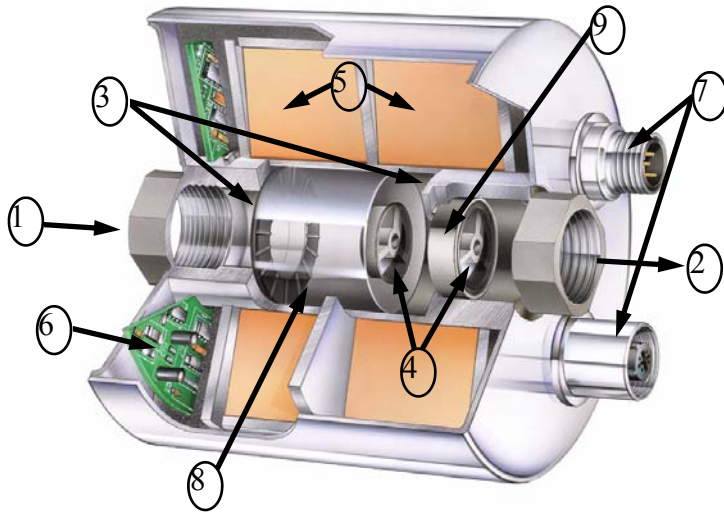

- | | |
|-----------------|-----------------------|
| 1. Inlet | 6. Circuit Board |
| 2. Outlet | 7. Cordset Connectors |
| 3. Bumpers | 8. Piston |
| 4. Check Valves | 9. Insert |
| 5. Coils | |

Note: Cutaway is typical of PW2000 Series. Exact configurations vary slightly within series.

REPLACEMENT PARTS

Item #	Part #	Description	Qty
3	100024-100	Bumper (Fluorel)	2
3	100024-200	Bumper (Neoprene)	2
3	100024-300	Bumper (EPDM)	2
4	100025-100	Check Valve (Fluorel)	2
4	100025-200	Check Valve (Neoprene)	2
4	100025-300	Check Valve (EPDM)	2
9	100026-200	Insert, 2 spoke	1
-	100029-100	Insert Retaining Ring	1
-	100030-100	Insert O-ring (Fluorel)	1
-	100030-200	Insert O-ring (Neoprene)	1
-	100030-300	Insert O-ring (EPDM)	1
-	20057	Elastomer Kit (Fluorel)	1
-	20058	Elastomer Kit (Neoprene)	1
-	20059	Elastomer Kit (EPDM)	1

PW2003-9/00



PUMPWORKS INC.
LIQUID & GAS TRANSFER TECHNOLOGY

2277 49th Avenue North
Brooklyn Center, MN 55430 USA

sales@pumpworks-inc.com
www.pumpworksinc.com



Distributed By:

Phone: 612-521-9331
Toll Free: 1-800-431-4408
Fax: 612-521-9397